



MACNAUGHT®

The experts in fluid technology

GBP2
1000
0001

GBP1 BEARING PACKER

Thank you for purchasing a Macnaught GBP1 Bearing Packer. The Macnaught bearing packer has been designed for use with standard grease guns or the Macnaught J2 grease filler pump.

Macnaught also manufacture a complete range of retractable hose reels, oil dispensing nozzles, fuel pumps, oil pumps, positive displacement flowmeters, greasing equipment and a complete range of accessories to suit any of your fluid handling requirements.

GENERAL INFORMATION

Please take a few moments to read through this manual before using your GBP1 Bearing Packer. This bearing packer is suitable for bearing sizes from 1/2" (13mm) inside diameter, a maximum of 5" (125mm) outside diameter and a maximum of 2" (50mm) high. If you experience any problems with this product, please contact your nearest Macnaught Distributor, or Authorised Macnaught Service Centre.

ASSEMBLY.

Refer to figure 1 for diagram of cover plate orientation and bearing packer assembly.

- 1) Fit and rotate the lower cover plate (2) down the shaft (4) as far as it will go.
- 2) Place the bearing squarely on the top of the lower cover as shown in fig 1.
- 3) Screw the top bearing cover (1), onto shaft (4) and lock the bearing firmly into position as shown. To remove the bearing remove the top bearing cover (1) only.

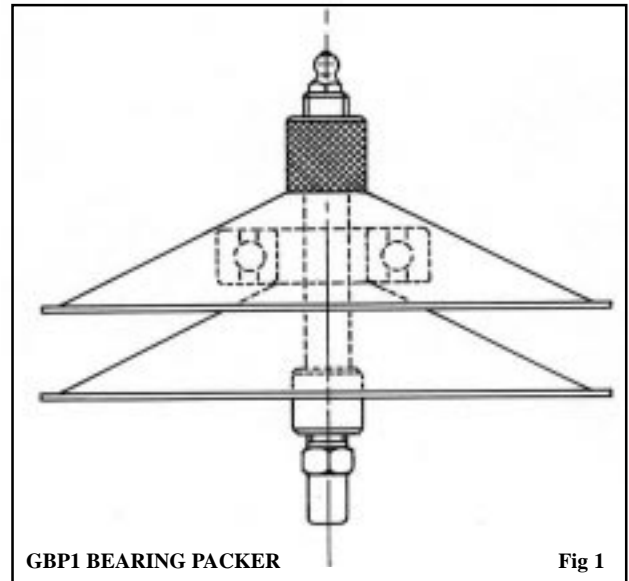

GBP1 BEARING PACKER

Fig 1

OPERATION

The Bearing packer can be used to load grease into a bearing with either with a conventional grease gun or with the Macnaught J2 grease filler pump.

- 1) When using a grease gun to pack your bearing attach the coupler on the grease gun to the grease nipple (3) on your bearing packer.
- 2) When using the J2 filler pump to pack your bearing, attach the special J2 grease filler adapter (5) on the Bearing packer to the outlet nozzle on the J2 filler pump. Holding the bearing packer firmly in place you can now easily pack your bearing .

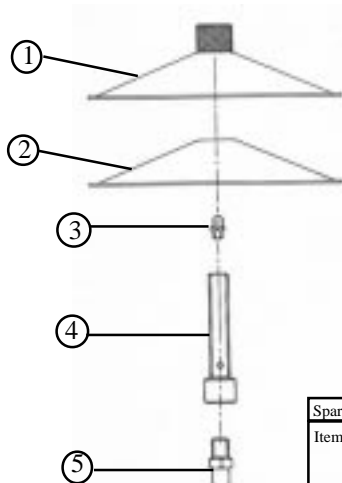

Spare Parts Available	
Item No	Part No
3	N391s
5	KF85

WARRANTY

Macnaught Limited ("Macnaught") warrants that the products (except for hoses) will be free from any defects caused by faulty material or workmanship for a period of twelve (12) months from the date of sale of the products to the end user (the "warranty period") PROVIDED THAT, during the Warranty Period:

1. Macnaught receives notice setting out full details of any defect in any product and details of the time and place of purchase of the product; and
2. The enduser, at its own cost returns the product to the nearest authorised Macnaught Service Centre.

Macnaught shall, at its own option repair or replace any product found to be defective by its inspection or refund the price paid by the enduser for that product.

Macnaught's liability and the enduser's rights under this Warranty shall be limited to such repair, replacement or refund and in particular, shall not extend to any direct, special, indirect or consequential damage or losses of any nature.

NOTE: This warranty does not form part of, nor does it constitute, a contract between Macnaught and the enduser. It is additional to any warranty given by the seller of the products and does not exclude, limit, restrict or modify the rights and remedies conferred upon the enduser, or the liabilities imposed on the seller, by any statute or other laws in respect of the sale of the product.