

J2 GREASE FILLER PUMP AND J2B DRUM PUMP

Thank you for purchasing either a Macnaught model J2 or J2B Drum Pump.

The J2 and J2B grease pumps are suitable for use with greases up to and including NLGI No2 consistency.

Please read and retain this instruction sheet to assist you in the assembly and maintenance of this product.

ASSEMBLY

Step 1

Push down the Follower Disc with the boss to the top, until grease shows



Step 2

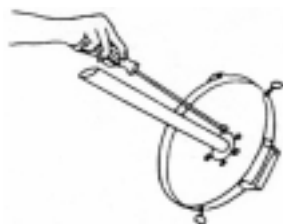

Fit Pump assembly (with the pump outlet positioned as shown in step 3) to the lid using the 3 screws provided.

Step 3

Place the unit on the pail and press down until it sits on the pail rim



Step 4

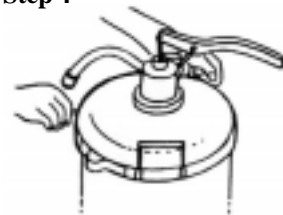

Adjust the thumb screws lightly under the pail rim

Step 5

Fit the end of the handle to the end of the piston rod with the pin and self-locking ring provided



Step 6

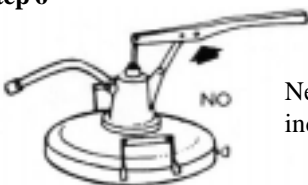

Never shift the link to the hole indicated

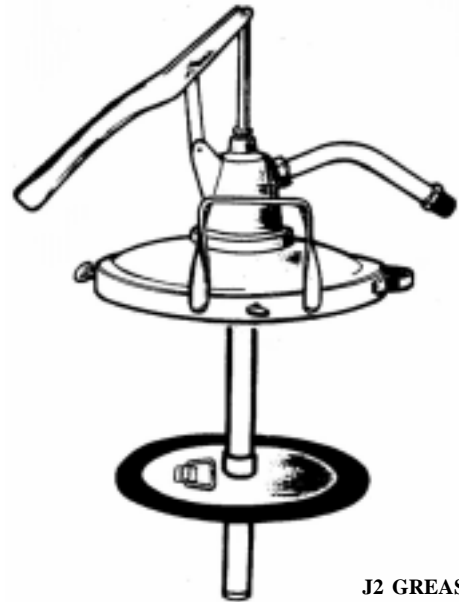

J2 GREASE PUMP

REFILLING GREASE GUNS



The J2 is designed to bulk fill most types of grease guns on the market. For those guns fitted with either a plug or bleed valve fitting (1/8" BSP thread) fit a Machaught KF85s Filler Bleeder Assembly

If you have or buy a Macnaught K6 Mini-Lube, and you prefer to fill the 2.5 kg container from 20 kg pails rather than buy your grease in 2.5 kg containers. Then refill the container with the J2 Grease pump.



When the 2.5kg tin is empty leave the follower on the bottom of the container. Push the grease pump nozzle into the boss on the follower disc, and pump tin full of clean grease, airlock free.

PARTS DIAGARM

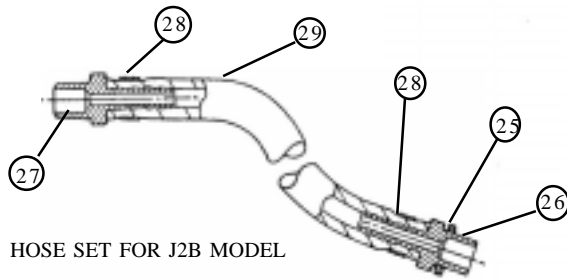

HOSE SET FOR J2B MODEL

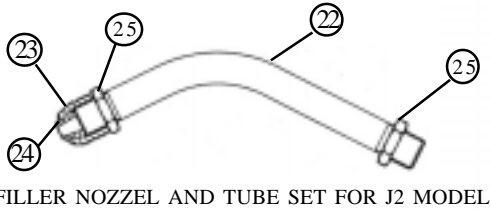

FILLER NOZZEL AND TUBE SET FOR J2 MODEL

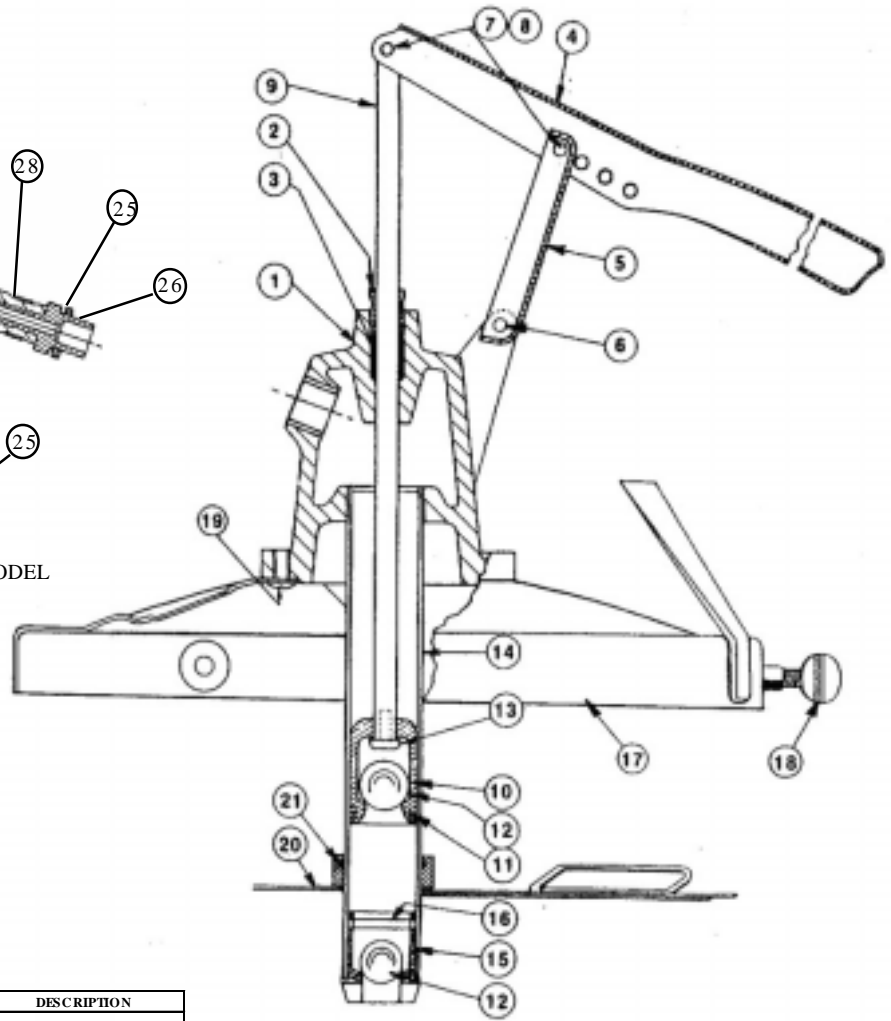

PARTS LIST

ORDER FOR REPLACEMENT					
ITEM	No Of	PART No	PART / SET	KIT. REF	DESCRIPTION
			J2-1K (Kit A)		SEAL KIT FOR J2
			J2B-1K (Kit B)		SEAL KIT FOR J2B
1	1	J71	J71s	A B	BODY
2	1	AA5	AA5s	A B	GLAND NUT SET
3	1	AA6			GLAND PACKING
4	1	AA3			HANDLE
5	1	AA4			LINK
6	1	N335	AA7s		LINK PIVOT PIN
7	2	AA16			PIVOT PIN
8	2	N255			PIVOT PIN RETAINER
9	1	J53	J53s (for 20 kg)		PISTON ROD (20kg)
9	1	J54	J54s (for 28-35lb)		PISTON ROD (28-35lb)
10	1	KA59			PISTON
11	1	BS212		A B	ORING
12	2	N420		A B	3/4" STEEL BALL
13	1	N31		A B	SCREW
14	1	J74	J74s		PUMP TUBE (20kg)
14	1	J88	J88s		PUMP TUBE (28-35lb)
15	1	AG54	AG54s (incl N420)		FOOT VALVE
16	1	N329			FOOT VALVE PIN
17	1	J51			LID SET
18	3	N21	J72s	A B	THUMB SCERWS
19	3	N52		A B	GUTTER BOLTS
20	1	J11	J11s (incl BS218)		FOLLOWER DISC (20kg, 35lb)
20	1	J77	J77s (incl BS218)		FOLLOWER DISC (28lb)
21	1	BS218		A B	ORING
22	1	J7			OUTLET TUBE
23	1	J62	J62s (J2 ONLY)		OUTLET NOZZLE
24	1	J63		A	NOZZLE SEAL
25	2	N208			LOCK NUT (2 X J2 and 1 x J2B)
26	1	N435			HOSE TAIL
27	1	N434			HOSE TAIL
28	2	Z47	KH42s (J2B ONLY)		HOSE CLAMP
29	1	KH47			HOSE

TROUBLE SHOOTING GUIDE

TROUBLE	CAUSE	REMEDY
Pump jammed, hard to operate.	Link is in the wrong position on the handle	Move the link to the hole shown in drawing above.
Pump does not pump grease	a) Follower o'ring is damaged or missing.	a) Replace follower o'ring (21)
	b) Dented pail	b) Tilt the edge of the follower below the dent.
	c) Foreign body on the piston valve seat	c) Unscrew the pump tube and clean piston. Inspect foot valve seat (15)
	d) Piston o'ring damaged	d) Follow steps in item (c), then replace piston o'ring (11)

WARRANTY POLICY

Macnaught Limited ("Macnaught") warrants that Products purchased after 1st of July 1999 will be free from any defects caused by faulty materials or workmanship for a period of (5) years from the date of purchase of the product.

For componentry contained in the product which are subject to wear, the warranty period will be (12) months from the date of purchase of the product.

Provided that during the Warranty period:

- 1) Macnaught receives notice setting out full details of any defect in any product and details of the time and place of purchase.
- 2) The Purchaser, at their own cost returns the product to the nearest authorized Macnaught service center.

Macnaught shall, at its option repair or replace any product found defective by its inspection. This warranty does not cover failure of parts or components due to normal wear or damage, which in the judgment of Macnaught, arises from misuse, abrasion corrosion, negligence, accident, substitution of non-Macnaught parts, faulty installation or tampering. If Macnaught inspection discloses no defect in material or workmanship, repair or replacement and return will be made at customary charges.

Macnaught's liability and the purchaser's rights under this Warranty shall be limited to such repair or replacement and in particular, shall not extend to any direct, special, indirect or consequential damage or losses of any nature.

The foregoing warranty supersedes, voids and is in lieu of all or any other warranties.

Note:

This warranty does not form part of, nor does it constitute, a contract between Macnaught and the purchaser. It is additional to any warranty given by the seller of the products and does not exclude, limit, restrict or modify the rights and remedies conferred upon the purchaser, or the liabilities imposed on the seller, by any statute or other laws in respect of the sale of the product.



Macnaught Pty Ltd
 PO Box 90 Arncliffe NSW 2205 Australia
 Telephone (02) 9567 0401
 Facsimile (02) 9597 7773