

# **Balcrank<sup>®</sup>**

CE

## **P-SET ELECTRONIC PRESET CONTROL HANDLE**

**Model 3331-014  
(with Semi-Automatic Tip)  
Model 3331-012 (Bare)**



Thoroughly read and understand this manual before installing, operating or servicing this equipment.

---

**OPERATION, INSTALLATION,  
MAINTENANCE AND REPAIR GUIDE**

## General Safety

Thoroughly read and understand this manual before installing, operating or servicing the described products.

	<p><b>▲ IMPORTANT</b></p>
<p>Because this control handle can be incorporated into a pressurized systems, the following safety precautions should be observed.</p>	
<p>Check equipment regularly and repair or replace worn and damaged parts.</p>	
<p>Never alter or modify any parts of this control handle, doing so may cause damage to the control handle and/or personal injury.</p>	
<p>Under no circumstances should the dispensing valve be aimed at any person at any time. Personal injury may result.</p>	
<p>Release pressures built up in the system before any service or repair is begun. See the pressure relief procedure below.</p>	
<p>Do not operate this control handle above the maximum operating pressure of 1500 psi.</p>	
<p>Always read and follow the fluid manufacturer's recommendations regarding the use of protective eye wear, clothing and respirators.</p>	

	<p><b>▲ WARNING</b></p>
<p>Pressure Relief Procedure:</p>	
<p>Follow this procedure whenever you shut off the pump, when checking or servicing any part of the system and when installing, cleaning or changing any part of the system.</p>	
<ol style="list-style-type: none"> <li>1) Disconnect the air to the pump.</li> <li>2) Point dispensing valve away from yourself and others.</li> <li>3) Open dispensing valve until pressure is relieved.</li> </ol>	

	<p><b>▲ WARNING</b></p>
<p>A manual tip cannot be used on P-Set control handle. An auto tip must be used. Use of a manual tip can result in overpressurization, which can cause control handle to crack.</p>	

	<p><b>▲ WARNING</b></p>
<p>DANGER: Not for use with fluids that have a flash point below 100°F (38°C). Examples: gasoline, alcohol. Sparking could result in an explosion which could result in death.</p>	

	<p><b>▲ WARNING</b></p>
<p>Airborne particles and loud noise hazards. Wear ear and eye protection.</p>	

	<p><b>▲ WARNING</b></p>
<p>Do not place your hand or fingers over the dispensing nozzle and/or aim the nozzle at a person at any time. Personal injury may result.</p>	

## General Description

This manual assists you in operating and maintaining your new P-SET Electronic Preset Control Handle. The information contained will help you ensure many years of dependable performance and trouble free operation.

Please take a few moments to read through this manual before installing and operating your new control handle. If you experience problems with this product, refer to the trouble shooting sections of this manual. If you require further assistance please contact your local Balcrank® distributor or Balcrank® authorized service center.

## Specifications

<b>Accuracy:</b>	+ - 1% (of Reading)
<b>Flow Range:</b>	0.26 – 8 gal/min
<b>Maximum Operating Pressure:</b>	1,500 PSI
<b>Weight:</b>	2.55 lbs
<b>Inlet:</b>	½" NPT
<b>Outlet:</b>	3/8" NPT (prior to 6/03) 3/8" NPS (after 6/03)
<b>Operating Temperature:</b>	32° – 122°F
<b>Wetted Parts:</b>	Aluminium, Acetal, Steel, Nitrile Rubber
<b>Fluid Compatibility:</b>	Engine Oil, Diesel Oil, Automatic Transmission Fluid, Anti-freeze
<b>Pressure Loss:</b>	14.4PSI at 3.2 US gal/min with calibration fluid (6 Centipoise viscosity) without extension.
<b>Dimensions:</b>	10 inch Long x 3.7 inch Wide, 4.33 inch High (Dimensions without extension)

## Assembly

Use Teflon® tape (or suitable thread sealant) when connecting the control handle to the hose connection.

## Outlet Extension

The outlet extension can be fitted either inline (forward) or on the outlet port "pistol style" located under the meter.

**Note:** The threaded plug removed from the outlet port on the underside of the meter, is used to seal the outlet port not in use.

## Handle Operation

To latch the handle, press the lever, push the button and then release the lever.

To release the latch, in manual or automatic mode, simply press and release the lever.

When the control handle is in automatic mode the lever will release automatically once the preset volume has been dispensed.



### ▲ WARNING

A manual tip cannot be used on P-Set control handle. An auto tip must be used. Use of a manual tip can result in overpressurization, which can cause control handle to crack.

## Meter Introduction

### *Operating mode description.*

**Sleep Mode:** To minimize battery consumption the meter will revert to sleep mode if left idle for more than 2 minutes, and will automatically "power up" when the *reset/auto* or *reset/alarm* buttons are pressed or there is flow through the meter.

**Manual Mode:** For manual operation. No status segments displayed.

**Auto Mode:** For auto shut off operation Auto segment flashing.

**Alarm Mode:** Pre audible warning Alarm segment flashing.

**Reset Mode:** Displays the re-settable accumulative total.

**Setting Mode:** Provides access to meter settings.

- Change Preset volumes.
- Unit settings. (gallons liters, etc.).
- Options setting.
- Calibration. (Factory setting).

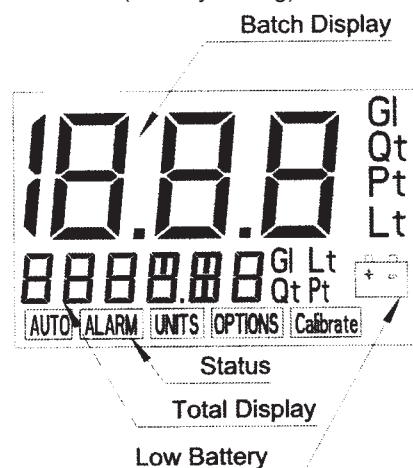

## Operation of Buttons

The control buttons can be used in two ways

- 1) **Press:** Press & release the button.
- 2) **Double click:** Press & release the button twice quickly.

## Totalizers

There are three totalizers built in to your meter

- 1) **Reset batch total:** To reset batch total press the *reset* button.
- 2) **Non-reset accumulative total:** This is located below the batch total and displays the total volume the meter has dispensed.
- 3) **Reset accumulative total:** Is hidden from view and is used to track daily, weekly, or monthly usage.

## To View or Reset Total

- a) If not in manual mode, *double* click the *reset* button to return to manual mode (no mode segments will be visible)
- b) *Double* click the *reset* button (the display will enter the reset total mode)
- c) To reset total, press and hold the *reset* button (3 seconds) until the total zeros.
- d) The display will automatically return to manual mode after 5 seconds, or alternatively *double* click the *reset* button.

## Manual Operation

Pull the control handle lever to control oil flow throughput, opening or closing the lever will vary flow rate.

## Auto / Alarm Mode

In auto mode the meter can be programmed to automatically shut-off after having dispensed the preset volume.

In alarm mode the meter will sound an audible alarm at 0.5 units prior to preset volume.

## Presetting Dispense Volume

Press *auto* or *alarm* button (The display will flash and read the last volume dispensed)

- 1) To change volume, press the 10, 1 or 0.1 buttons to enter the required volume.
- 2) To dispense the preset volume press lever and latch.
- 3) To reset the volume to zero press *reset*.

## Pre-Programmed Volume

- 1) Press *auto* or *alarm* button. Each press of the *auto* or *alarm* button will cycle through the five preset volumes.
- 2) Stop at the required volume, press and latch lever.

**NOTE:** The P-SET Electronic control handle automatically shuts off at the preset volume.

## Pre-Programmed Volumes

- A) If not in manual mode *double* click the *reset* button.
- B) Press and hold the *reset* and *auto* or *alarm* buttons until the display shows "PRES 1"
- C) Press and release either the *auto* or *alarm* button to cycle through the five preset volumes. Stop at the preset volume to be changed.
- D) To change the preset volumes press the 10, 1, or 0.1 buttons to obtain the desired volume.

- E) Press either the *auto* or *alarm* button to store the new volume.

To return to defaults press *reset* button for 3 seconds. To return to manual mode *double* click the *reset* button a further four times.

## Changing Units

- 1) Press and hold the *reset* and *auto* or *alarm* buttons together until "PRES 1" appears.
- 2) *Double* click the *reset* button. (The batch, accumulative total units, and the units segment will be flashing.)
- 3) Press either the *auto* or *alarm* button to cycle through the unit options.
- 4) Stop at the required setting.

### Batch Total - Accumulative Total

Liter	Liter
Pint	Gallon
Quart	Gallon
Gallon	Gallon

When complete *double* click the *reset* button to enter options setting mode.

**Note:** If you do not want to change the options settings *double* click the *reset* button twice to return to manual mode.

## Option Settings

- 1) In manual mode press and hold the *reset* and *auto* or *alarm* until the display shows "PRES 1".
- 2) *Double* click the *reset* button twice to enter the options setting.
- 3) Press either the *auto* or *alarm* to cycle through the options.
  - A. Batch resets to zero on waking (on/off)
  - B. Batch counts up or down (up/down) in *auto*/*alarm* mode
  - C. Turn Beeper on or off (on/off)
  - D. N/A
  - E. Factory setting (fixed)

- 4) Press any one of the 10, 1 or 0.1 buttons to change the option preference.

After completing meter option settings *double* click the *reset* button to enter calibration mode. *Double* click *reset* to go to normal operation.

Note: Calibration mode, factory option. To reset the calibration factor to default settings, press and hold *reset* button for 3 seconds.

## Low Battery

The battery segment will flash when the battery is low and needs replacing.

The control handle will not operate in auto mode when the battery is low, although the gun can still be used in manual mode.

**NOTE:** When the battery segment starts flashing replace the battery as soon as possible.

## Battery Replacement

- 1) Remove the protective boot.
- 2) Remove the battery cover screw located near the inline (forward) outlet port and remove the battery cover.

- 3) Replace the two AA Alkaline batteries. (Check + - are correct)
- 4) Inspect the battery cover seal for damage and replace if necessary.
- 5) Replace battery cover and tighten screw, while pressing cover in place.

## Error Message

If an error is detected in meter operation, the following error codes will appear on the display.

**Err1 – Sensor error**

**Err2 – Auto shut off failure**

**Err3 – Flow rate too high**

**Err4 – Calibration error**

**Err5 – Computer error**

To reset the meter after an error message press *reset*.

## Maintenance

Inspect your control handle daily for any signs of damage. Replace any damaged parts or components as required.

	<b>WARNING</b>
Pressure Relief Procedure:	
<p>Follow this procedure whenever you shut off the pump, when checking or servicing any part of the system and when installing, cleaning or changing any part of the system.</p> <ol style="list-style-type: none"> <li>1) Disconnect the air to the pump.</li> <li>2) Point dispensing valve away from yourself and others.</li> <li>3) Open dispensing valve until pressure is relieved.</li> </ol>	

## Handle Disassembly

Use a clean work area to carry out maintenance.

- A) Remove the fluid hose from the control handle inlet swivel (31).
- B) Unscrew and remove swivel (31), washer (29), and o-ring (30) from the control handle inlet. Clean or replace the strainer and o-ring.  
**CAUTION: The swivel is under spring tension.**
- C) Slide off the handle sleeve (28).
- D) Remove valve spring (27), seal/valve body assembly (25,26) and plunger (24).

## Lever and Valve Removal

- A) Using a 2.5mm allen wrench, remove the two handle screws (32).
- B) Remove lever (34).
- C) Remove the washer (20) and o-ring (19), then push the valve cam (16) from the handle body (15), and remove o-ring (19).

## Handle Reassembly

- A) Clean and inspect all parts. Replace any suspect, worn, or damaged components.

**Note:** Lightly lubricate the valve cam before assembly.

- B) Place o-ring (19) onto valve cam (16).  
**Note:** The cutout section in the middle of the valve cam (16) must face the inlet swivel (31).
- C) Replace the valve cam (16) into the body (15). Note the orientation shown on the assembly drawing. Fit the second o-ring (19) and washer (20).
- D) Slide lever assembly (34) into position and replace the two allen screws (32). Use loctite or similar sealant.
- E) Replace plunger (24).  
**Note:** The end hole in the plunger must face the meter.
- F) Assemble the seal/valve body (25, 26) and spring (27) and replace into the handle body.  
**Note:** Install the spring, small end first.
- G) Replace handle sleeve (28).
- H) Replace washer (29), o-ring (25), and swivel assembly (31) and screw firmly into place. Use Loctite or similar sealant.

## Meter Disassembly

- A) Unscrew the swivel assembly (31) two complete turns to allow easy disassembly and reassembly of the meter and remove boot (1).
- B) Remove battery cover screw (5) and batteries (9).
- C) Remove the three screws (11) and the calibration port screw (18) from the underside of the meter.
- D) Carefully remove the computer module (2) from the module housing (10).  
**Note:** The computer module is non repairable and will need to be replaced if damaged.
- E) Remove the four allen screws (17) from the underside of the meter and remove the module housing (10).

## Meter Reassembly

- A) Clean and inspect all parts. Replace any suspect, worn, or damaged components.
- B) Replace rotors (13).  
**Note:** Ensure the rotor with the magnets is assembled with the magnets facing up and positioned on the correct side of the meter. Both rotors must also be positioned at 90 degrees to each other.
- C) Replace the handle body o-ring (14).
- D) Carefully position the module housing, (10) on top of the handle body (15), replace and tighten the four allen screws (17).
- E) Test the control handle for correct operation.
- F) Replace the computer module (2).
- G) Replace and tighten the three phillips head screws (11) and calibration port screw (18).
- H) Replace the two AA Alkaline batteries (9). Use the directions on the label found inside the battery housing for correct battery orientation.
- I) Replace battery cover assembly (6, 7, and 8) and tighten the screw (5).
- J) Firmly tighten the swivel assembly (31).
- K) Replace the boot (1).
- L) Test the control handle for correct operation.

## Calibration Procedure

- 1) Ensure all air is removed from the pumping system and the gun is fully primed and ready to operate.
  - 2) Remove the calibration screw (Item 18 on the parts list) from the underside of the gun.
  - 3) Enter the settings mode by pressing the RESET and AUTO buttons together (or RESET and ALARM buttons). The display will then show PRES 1.
  - 4) Double click the RESET button until the display segment shows Calibrate (the Calibrate segment will be flashing) the batch segments will show CAL and the smaller digits will display the offset value. This value will read 100000 if the gun has not been previously calibrated.
  - 5) To re-calibrate press the calibration micro-switch using a 3mm Diameter x 70mm long rod or similar through the Calibration screw hole. The Calibrate segment will stop flashing.
  - 6) Dispense a volume (say 15 litres) into a calibrated volume measuring reference or use a master meter.
- Record this value, say 15.08 litres. To improve the calibration accuracy dispense as large a volume as possible.
- 7) Enter the recorded value from step 6 (15.08) into the calibration screen using the 10, 1 and 0.1 Buttons to enter 15.0 and the AUTO or ALARM button to enter the 8 (second decimal).
  - 8) Once the value is entered press the Calibration micro-switch again as detailed in step 5) to accept the value. The large display will change to read 0.00 and the offset value will be displayed on the smaller digits (eg 100757). Confirm the calibration against a calibrated volume reference and refit the calibration screw.
- Note: If the offset is greater than 5% an error code (Err 4) will be generated.
- 9) To exit the calibration mode double click the RESET button twice.
  - 10) If the display goes to sleep (approx 2 minutes) during any of the above operations the process will need to be restarted.

## Troubleshooting

TROUBLE	CAUSE	REMEDY
No fluid passing through the meter	A. Blocked strainer	A. Clean or replace strainer
	B. Dirt particles jamming the rotors	B. Dismantle meter assembly and clean
	C. Damaged plunger seal	C. Replace damaged plunger seal
The meter is not registering fluid output	A. Dead battery	A. Replace battery
	B. No signal from the magnets	B. Check magnets
	C. Damaged computer module	C. Replace computer module
Meter display reads Err 1	Sensor error	Press the reset button to reset the computer (If the error repeats, check the magnets in the rotor)
Meter display reads Err 3	Flow rate too high	Adjust the flow rate to 0.26-8 US gal/min
		Eliminate air from the system
Meter display reads Err 4	Calibration error	Press the reset button to reset the computer
Meter display reads Err 5	Computer error	Press the reset button to reset the computer
Constant oil leak from the tip	Damaged plunger seal	Replace plunger seal (check for damage)
Intermittent drip from the tip	Dirt in the tip	Remove the tip and blow out any dirt particles, replace if necessary
Oil leak from the lever assembly area	Damaged o-rings	Replace damaged o-rings
Oil leak from between the body casting and the computer module casting	Damaged o-rings	Replace damaged o-rings
Low flow rate	Blocked strainer	Replace strainer
Oil leaking from the swivel inlet	Damaged o-ring or swivel	Replace o-ring or swivel

## P-Set Electronic Preset Control Handle Parts List

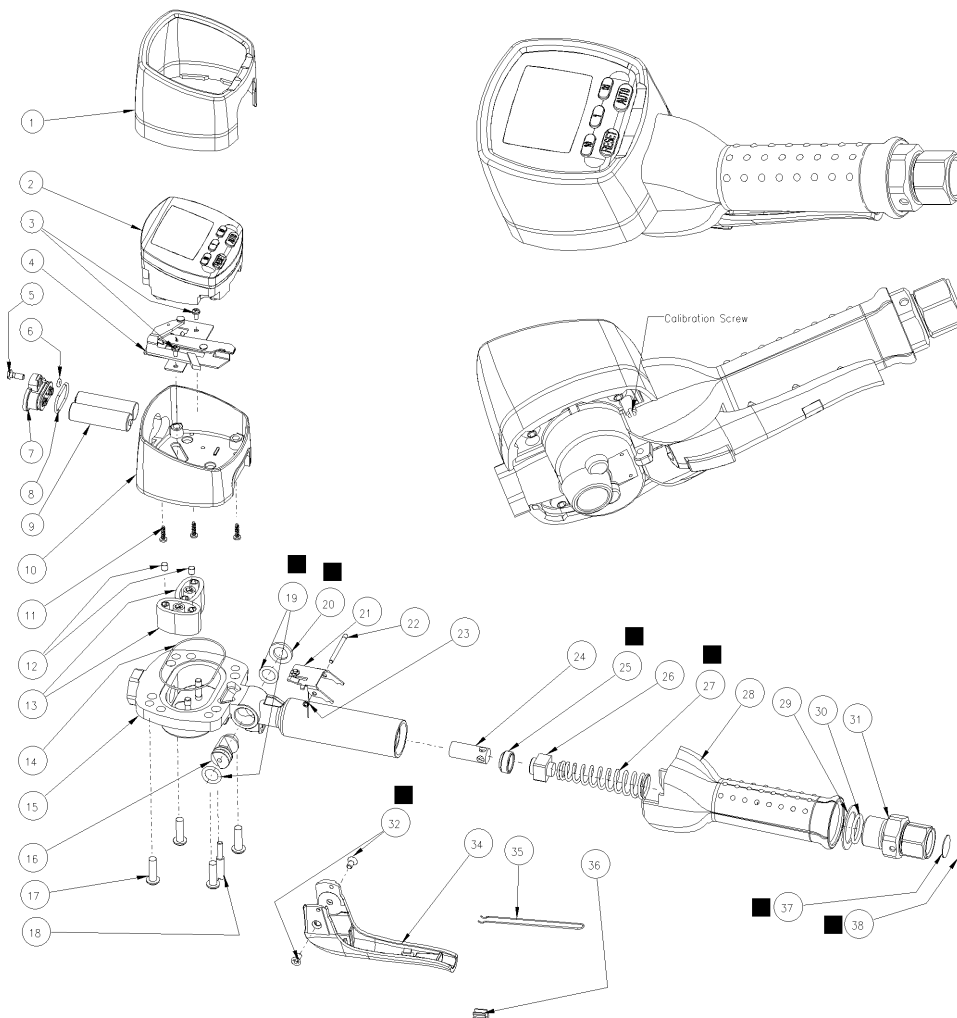

Item	Part No.	Qty.	In Kit	Description	Item	Part No.	Qty.	In Kit	Description
1	830727	1	-	Boot, P-Set	21	-	1	-	Latch Plate Assembly
2	830726	1	-	Module, P-Set	22	-	1	-	Latch Pivot Pin
3	-	2	-	Screws	23	-	1	-	Spring
4	-	1	-	Latch Release Assembly	24	-	1	-	Plunger
5	-	1	-	Battery Cover Screw	25	-	1	■	Seal
6	-	1	-	O-Ring	26	-	1	-	Valve Body
7	-	1	-	Battery Cover	27	-	1	■	Valve Spring
8	-	1	-	O-Ring	28	-	1	-	Handle Sleeve
9	-	2	-	AA Alkaline Batteries	29	-	1	-	Washer
10	-	1	-	Module Housing	30	-	1	-	O-Ring
11	-	3	-	Screws	31	830728	1	-	Swivel, Control Handle
12	-	2	-	Magnets	32	-	2	■	Screws
13	-	2	-	Oval Gear Set	34	-	1	-	Lever Latching
14	-	1	-	O-Ring	35	-	1	-	Button Spring
15	-	1	-	Control Handle Body	36	-	1	-	Lever Plug
16	-	1	-	Valve Cam	37	-	1	■	Mesh
17	-	4	-	Screws	38	-	1	■	O-Ring
18	-	1	-	Calibration Screw	39	3332-032	1	-	Semi-Automatic Tip (not shown) (prior to 6/03)
19	-	2	■	O-Ring	40	3332-045	1	-	Semi-Automatic Tip (after 6/03)
20	-	1	■	Washer*					

■ Control Valve Service Kit  
(Order 900013)

\* Prior to 7/03 (stamped on handle 0283) use metal washer.  
After 7/03 (stamped on handle 0293) use plastic washer.

# WARRANTY

All Balcrank® equipment sold by authorized Balcrank® distributors is warranted to their original customer to be free from defects in materials and workmanship for a period of one year from the date the equipment was sold to the original customer. Select equipment carries extended warranty terms as individually noted within the Balcrank® Lubrication Equipment & Accessories User Price List. Any Balcrank® equipment carrying an extended warranty will be warranted for the period indicated; those items carrying a “lifetime” warranty are warranted for a period of thirty years. All Balcrank® equipment determined by Balcrank® to have defective materials or workmanship within the one year warranty period will be repaired or replaced. For equipment carrying extended warranties Balcrank® will repair or replace the product including parts and labor for the first full year and will provide parts only for the remaining period of the specified warranty.

This warranty only covers equipment installed and operated according to applicable Balcrank® Service Bulletins and Installation Instructions. Any equipment claimed to be defective must be returned, freight prepaid, to an Authorized Balcrank® Service Center. If the part(s) or equipment is found to be defective, it will be repaired or replaced, and returned freight prepaid from the Authorized Service Center. If the claimed part(s) or equipment is found not to be defective, the Authorized Balcrank® Service Center will, upon written authorization being received from the original customer, repair them for a reasonable charge to the customer which will include all applicable parts, labor, and return transportation costs. Any equipment returned to Balcrank® must have the Warranty Service Claim number (WSC#) clearly marked on the outside of the carton. Balcrank's sole responsibility is for defects in material and workmanship, and Buyer's sole and exclusive remedy hereunder, shall be limited to repair or replacement of the defective part or equipment.

This warranty does not cover, nor shall Balcrank® be liable for repair or replacement of parts or equipment resulting from general wear and tear through use, or damage or failure caused by improper installation, abuse, misapplication, abrasion, corrosion, insufficient or improper maintenance, negligence, accident, alteration, or substitution of non-Balcrank component parts. Furthermore the Balcrank® Warranty for Lubrication Equipment and Accessories does not cover the following specific conditions:

- › Failure or damage to equipment that is caused by dirt or debris in air and fluid lines. This includes, but is not limited to clogged inlet filters, strainers, or regulators; fluid meters; control handles; fluid tips; and valves.
- › Failure of normal wear parts including but not limited to: “o”-rings, packings, seals and valves unless originally improperly installed by the factory.
- › Products placed in applications for which their use was not intended. Examples include but are not limited to: A lubricant pump being used to pump solvents, or placing a piece of equipment intended strictly for indoor use in an outdoor application.
- › Damage to equipment resulting from operation above and beyond Balcrank's recommendations.
- › Leaks at air and fluid fittings and connections.
- › Damage caused by thermal expansion when adequate pressure relief was not included in the system.
- › Loose suction tubes on pumps.
- › Reel spring tension adjustment.

**THERE ARE NO OTHER WARRANTIES, EXPRESSED OR IMPLIED, INCLUDING WARRANTIES OF MERCHANTABILITY OR FITNESS FOR A PARTICULAR PURPOSE. IN NO EVENT SHALL BALCRANK BE LIABLE FOR ANY SPECIAL, CONSEQUENTIAL, OR OTHER DAMAGES OF SIMILAR NATURE, INCLUDING BUT NOT LIMITED TO LOST PROFITS, LOST PRODUCTION, PROPERTY DAMAGE, PERSONAL INJURY, WHETHER SUFFERED BY BUYER OR ANY THIRD PARTY, IRRESPECTIVE OF WHETHER CLAIMS OR ACTIONS, LEGAL OR EQUITABLE, FOR SUCH DAMAGES ARE BASED UPON CONTRACTS, WARRANTY, NEGLIGENCE, STRICT LIABILITY, OR OTHERWISE. ANY CLAIM OR ACTION FOR BREACH OF WARRANTY MUST BE BROUGHT WITHIN TWO (2) YEARS FROM THE DATE OF SALE TO THE ORIGINAL CUSTOMER.**

Balcrank® Products Inc.  
115 Reems Creek Road  
Weaverville, NC 28787  
800-747-5300  
800-763-0840 Fax  
www.balcrank.com

Distributed by:

Revision Log:

SERVICE BULLETIN SB 3021  
Rev. G 11/06  
830351

Rev. E - changed to NPS thread at outlet.  
Rev. F - Added note about washer (item 20).  
Rev. G - Added Calibration Procedure.