



OS253
0202
0004

MACNAUGHT®

The experts in fluid technology

ASSEMBLY INSTRUCTIONS

TR205 Litre Trolley / OS100 Oil System / GS100 Grease System

Thank you for purchasing either a Macnaught TR205 Drum Trolley, OS100 Oil System or GS100 Grease System. All three Systems have been designed to suit 205 litre or 180kg drums.

Macnaught also manufacture a complete range of retractable hose reels, oil dispensing nozzles, fuel pumps, oil pumps, positive displacement flowmeters, greasing equipment and a complete range of accessories to suit all your fluid handling requirements.

GENERAL INFORMATION

Please take a few moments to read through this manual before using either your TR205 Trolley, OS100 Oil system or GS100 Grease System. **Please read and retain this instruction** to assist you on the assembly and installation of the products listed above. Pay special attention to any warnings or cautions mentioned in this instruction manual.

TR205 TROLLEY ASSEMBLY

The TR205 Trolley carton contains:

1 x Trolley base, 1 x Trolley handle assy, 2 x wheels, 1 x Brake Castor, 1 x Safety chain, 4 x 10mm x 25mm long Bolts, 4 x 10mm Nuts, 8 x 10mm Washers, 4 x 16mm Washers, 2 x Cotter pins, 2 x 5/16" x 1" long Set screws, 1x Instruction manual.

- 1) Remove all the components from the carton.
- 2) Fit a 16mm washer to the wheel axle on the trolley base.
- 3) Fit one of the wheels to the wheel axle.
- 4) Fit another 16mm washer after the wheel and secure the wheel in place with one of the cotter pins supplied.
- 5) Fit the other wheel to the trolley base as detailed above steps 2 to 4).
- 6) Line up the 4 holes on the Castor plate with the 4 mounting holes on the trolley base.
- 7) Secure the castor to the trolley base by using the 10mm bolts, washers and nuts supplied. Tighten all bolts and nuts securely.
- 8) Slide the trolley handle into position.
- 9) Secure the handle to the trolley base by fitting the two 5/16" set screws to the screw holes located directly under the handle on the under side of the trolley.
- 10) The Safety chain is attached to the hooks located on either side of the handle.

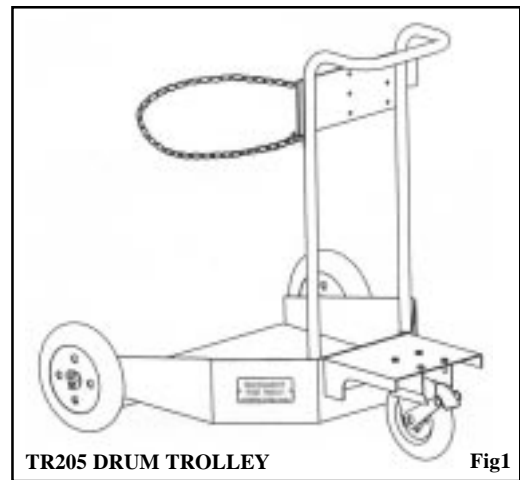

Caution

- * Do not leave the trolley on an incline or unattended.
- * Always apply the wheel brake when the trolley is not being moved.
- * Always use the safety chain to secure the drum.
- * Always disconnect the air supply before moving the trolley.

HOW TO USE THE CASTOR BRAKE

- 1) Press brake lever down to lock.
- 2) Lift the brake lever to unlock

Note: To adjust the brake tension, tighten the cross bolt holding the brake. Check brake function weekly.

FITTING THE DRUM ON THE TROLLEY

- 1) Tilt the drum and slide the trolley as far under the drum as possible.
- 2) Press the brake lever on the castor "down" to lock the trolley in position.
- 3) Slide the drum Fully into position on the Trolley.
- 4) Secure the safety chain around the drum.

OS100 OIL SYSTEM ASSEMBLY

OS100 OIL SYSTEM ASSEMBLY

The OS100 Oil System carton contains:

1 x TR205 Trolley (Trolley contents listed on page 1), 1 x R300S Oil pump, 1 x OLP100 Oil Reel, 1 x Oil Gun, 1 x Suction Hose (3/4" 1.5m), 1 x Feeder hose (1/2" x 1m), 2 Piece Suction Tube, Bung Adapter, Pump Mounting Bracket, plus fittings.

- 1) Remove all components from the carton.
- 2) Fit the castor and trolley wheels to the trolley base as described on page 1 (TR205 Trolley Assembly items 2-7).
- 3) Fit the pump mounting bracket (9) to the support plate on the trolley handle (refer to fig 3) using the 8mm screws, nuts and washers (8) supplied.
- 4) Slide the leg of the trolley handle, from the top of the reel (3) down through the reel mounting holes.
- 5) Slide the plastic washer up the trolley leg to the reel, followed by the support collar (14). Secure the support collar to the trolley leg by fitting the self tap screw supplied through the support collar into the hole located on the trolley leg.
- 6) Slide the trolley handle and reel assembly into position on the trolley base.
- 7) Secure the handle to the trolley base by fitting the two 5/16" set screws to the holes located directly under the handle on the underside of the trolley base.
- 8) Screw the pump bung adapter into the mounting bracket, then slide the pump into position and lock the pump firmly into position.

Note: Use a suitable thread sealant (eg. Teflon tape) on all screwed fittings but do not over tighten to avoid component damage.

- 9) Screw the top and bottom Suction Tubes firmly together.
- 10) Screw the 3/4" BSP Male fitting on the suction hose to the oil inlet on the bottom of the pump and tighten securely.
- 11) Screw the 90° elbow on the other end of the suction hose onto the thread adapter located on top of the suction tube and tighten securely.
- 12) Slide the Bung Adaptor assembly onto the Suction Tube and tighten to stop it from sliding down the tube.
- 13) Slide the Suction Tube assembly into the oil drum, release the clamp screw holding the bung adaptor and screw the bung adaptor firmly into place, then re-tighten the bung adaptor clamp screw.
- 14) Screw the feeder hose to the oil outlet on the pump using the 3/4" (M) x 1/2" (F) pump adaptor supplied.
- 15) Screw the remaining end of the feeder hose to the reel using the 1/2" (F) x 3/8" (F) reel adaptor supplied.
- 16) Screw the Oil Gun swivel on to the hose outlet on the oil reel.

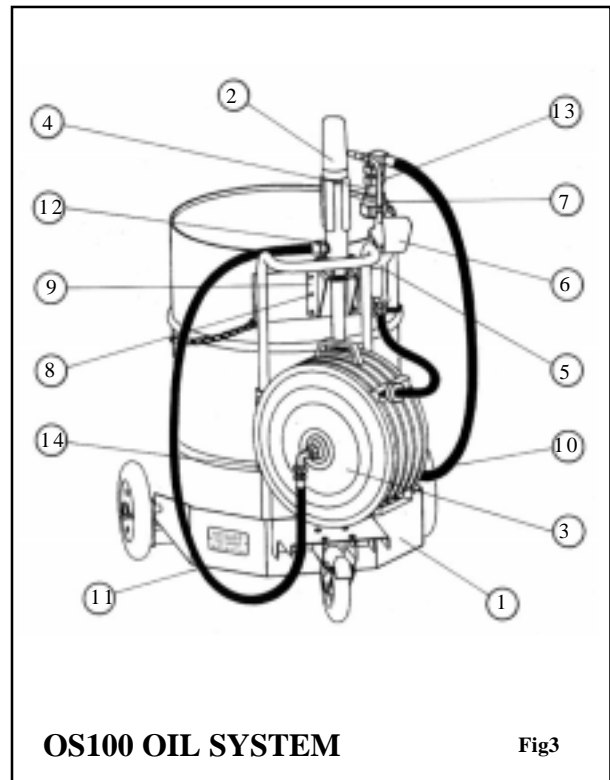

Note: Use the Oil Gun Hanger located on the trolley handle to secure the Oil Gun when the system is not in use.



Caution

Make sure all connections are tight before connecting the air supply.

After connecting the air supply, check for any oil leaks at hose connections. Tighten connections as required.

Do not use Air Pressure greater than 10 BAR/ 1000kPa/ 145 PSI

Disconnect the air line, press the oil gun trigger to release oil line pressure before carrying out any maintenance.

Please refer to the individual product specific instruction sheets for product maintenance and trouble shooting information.

FITTING THE DRUM ON THE TROLLEY

- 1) Tilt the drum and slide the trolley as far under the drum as possible.
- 2) Press the Brake Lever on the castor "down" to lock the trolley in position.
- 3) Slide the drum fully into position on the trolley.
- 4) Secure the safety chain round the drum.

GS100 GREASE SYSTEM ASSEMBLY

GS100 GREASE SYSTEM ASSEMBLY

The GS100 Grease System carton contains:

1 x TR205 Trolley (Trolley contents listed on page 1), 1x P8 Grease Pump, 1 x Lid and Follower set, 1 x Grease Feeder hose, GR100 Grease reel, 1 x B2 Booster Grease Gun, with ZSB Swivel

- 1) Remove all components from the carton.
- 2) Fit the castor and trolley wheels to the trolley base as described on page 1 (TR205 Trolley Assembly items 2-7).
- 3) Slide the leg of the trolley handle, from the top of the reel down through the reel mounting holes.
- 4) Slide the plastic washer up the trolley leg to the reel, followed by the support collar. Secure the support collar to the trolley leg by fitting the self tap screw supplied, through the support collar into the hole located on the trolley leg.
- 5) Slide the trolley handle and reel assembly into position on the trolley base.
- 6) Secure the handle to the trolley base by fitting the two 5/16" set screws to the holes located directly under the handle on the underside of the trolley base.

Note: Use a suitable thread sealant (eg. Teflon tape) on all screw fittings but do not over tighten to avoid component damage.

- 7) Position the grease pump follower centrally in the grease drum and hook the follower handle chain over the edge of the drum
- 8) Place the grease pump lid on top of the drum. The weight of the pump will hold the lid on the drum, there is no need to secure the lid on the drum.
- 9) Insert the grease pump suction tube through the hole in the lid and follower. The pump is not connected to the lid to allow easy change over when the drum is empty.
- 10) Connect the fixed end of the PF8 2.5 m high pressure feeder hose to the pump outlet.
- 11) Connect the swivel fitting on the remaining end of the feeder hose to the inlet on the grease reel. (1/4" reel adapter supplied)
- 12) Connect the B2 Booster gun to the hose outlet on the reel.



Caution

Make sure all connections are tight before connecting the air supply. After connecting the air supply, check for any grease leaks at hose connections. Tighten connections as required.

Do not use Air Pressure greater than 10 BAR/ 1000kPa/ 145 PSI.

Never exceed the working pressure rating of any component in the system. The Grease pressure is 50 times the air pressure applied.

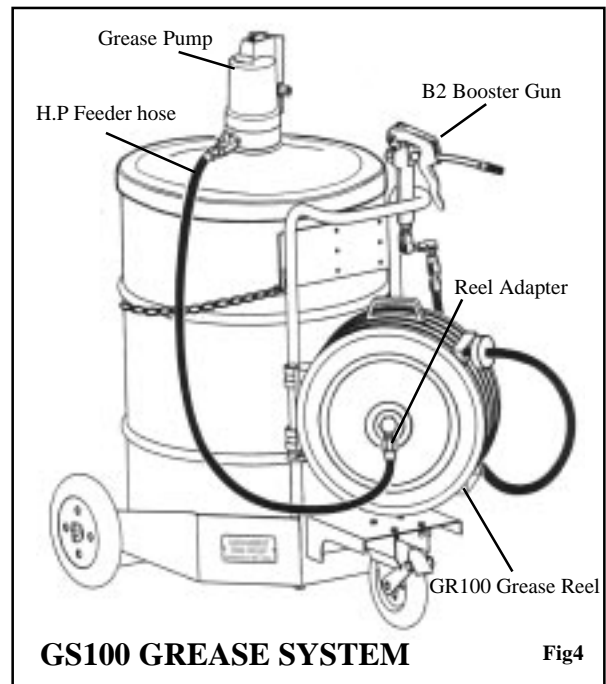

GS100 GREASE SYSTEM

Fig4



Warning

This system uses a high pressure grease pump. Because of the high working pressures developed by this pump weak or damaged hoses are a potential hazard.

Before each use, check hoses for signs of wear, leaks or loose fittings. Tighten all fluid connections regularly and replace weak or damaged hose. Your personal safety and well being are at stake.

Before attempting any maintenance or repairs of this product, disconnect the air supply then squeeze the gun trigger to release the fluid pressure.

DO NOT hit the pump if it fails to operate. Refer to the "Trouble Shooting Guide" in the P8 Instruction Manual or contact your Nearest authorised Macnaught Service Centre.

Please refer to the individual product specific instruction sheets for product maintenance and trouble shooting information.

FITTING THE DRUM ON THE TROLLEY

- 1) Tilt the drum and slide the trolley as far under the drum as possible.
- 2) Press the Brake Lever on the caster "down" to lock the trolley in position.
- 3) Slide the drum Fully into position on the Trolley.
- 4) Secure the safety chain round the drum.

PARTS DIAGRAM

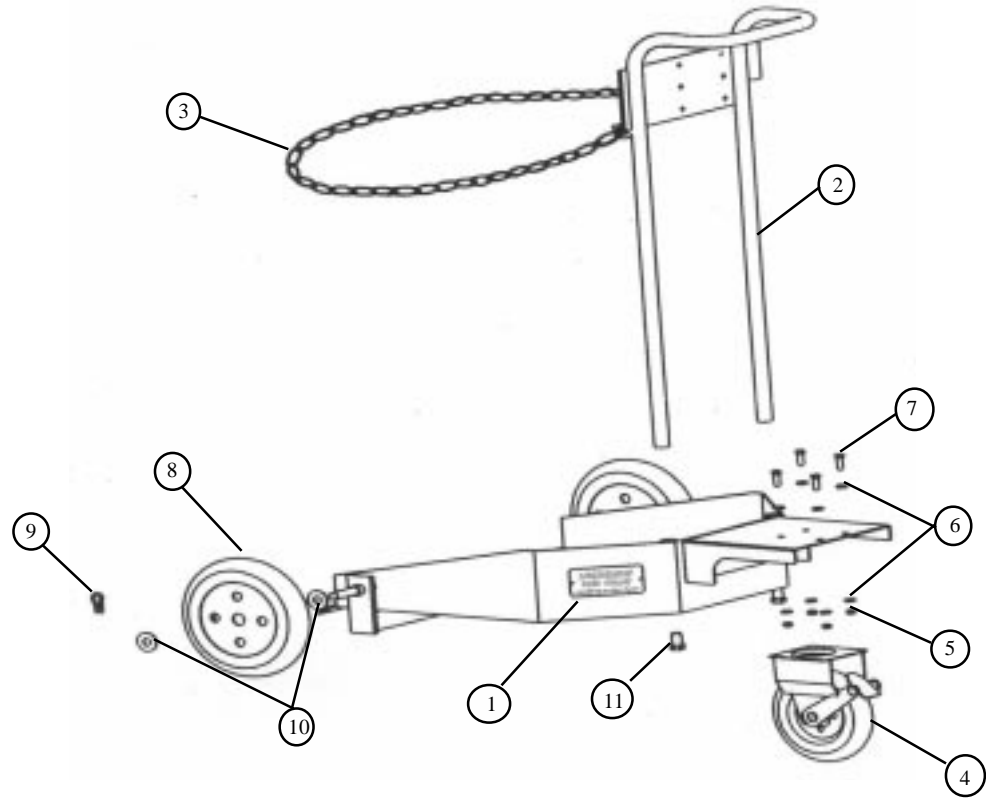

TR205 TROLLEY

Item	No off	Part or set	Kit. Ref	Part name
1	1	TR100		Trolley Base
2	1			Trolley Handle
3	1	TR100s		Safety Chain
4	1			Castor c/w Brake
5	4	TR106s	A	Nut
6	8		A	Washer
7	4		A	Bolt
8	2			Wheel
9	2	TR105s	A	Cotter Pin
10	4		A	Washer
11	2		A	Set Screw

Parts contained in Nut and bolt Kit TR205-1K "A"

OS100 OIL SYSTEM

Item	No off	Part or set	Kit. Ref	Part name
1	1	TR205		Trolley
2	1	R300S		R300S Oil Pump (3:1)
3	1	OLP100		OLP100 Oil Reel
4	1	GM38s		Suction Tube Assembly
5	1	*		Oil Gun
6	1	*		Oil Gun Boot
7	1	GR34S		Bug Adaptor Set
8	1	N51S		Nut & Bolt Set
9	1	TD20		Wall Bracket
10	1	RH109s		Suction Hose 3/4" x 1.5m(BSP)
11	1	RH108s		Feeder Hose 1/2" x 1m(BSP)
12	1	N384s		Reducing Bush (3/4" BSP (M) x 1/2" BSP (F))
13	1	TD113		Adaptor (3/4" BSP (M) x 1.344" UN (F))
14	1	RB5S		Support Washer / Collar Set

* Nominate Oil Gun Model and Boot colour when ordering replacement parts

GS100 GREASE SYSTEM

Item	No off	Part or set	Kit. Ref	Part name
1	1	TR205		Trolley
2	1	P8-11		P8-11 Grease Pump (complete)
3	1	GR100		Grease Reel
4	1	RB5s		Support Washer / Collar Set

WARRANTY POLICY

Macnaught Limited ("Macnaught") warrants that Products purchased after 1st of July 1999 will be free from any defects caused by faulty materials or workmanship for a period of (5) years from the date of purchase of the product.

For componentry contained in the product which are subject to wear, the warranty period will be (12) months from the date of purchase of the product.

Provided that during the Warranty period:

- 1) Macnaught receives notice setting out full details of any defect in any product and details of the time and place of purchase.
- 2) The Purchaser, at their own cost returns the product to the nearest authorized Macnaught service center.

Macnaught shall, at its option repair or replace any product found defective by its inspection.

This warranty does not cover failure of parts or components due to normal wear or damage, which in the judgment of Macnaught, arises from misuse, abrasion corrosion, negligence, accident, substitution of non-Macnaught parts, faulty installation or tampering.

If Macnaught inspection discloses no defect in material or workmanship, repair or replacement and return will be made at customary charges.

Macnaught's liability and the purchaser's rights under this Warranty shall be limited to such repair or replacement and in particular, shall not extend to any direct, special, indirect or consequential damage or losses of any nature.

The foregoing warranty supersedes, voids and is in lieu of all or any other warranties.

Note:

This warranty does not form part of, nor does it constitute, a contract between Macnaught and the purchaser. It is additional to any warranty given by the seller of the products and does not exclude, limit, restrict or modify the rights and remedies conferred upon the purchaser, or the liabilities imposed on the seller, by any statute or other laws in respect of the sale of the product.